

MORE LIGHT

Optical 3D Measurement Technology



Optical 3D Coordinate Measurement

For Analyzing, Manufacturing Inspection & Process Optimization

Based on structured light projection, non-contact 3D digitizing generates accurate 3D surface data in short time and high point density. Therefore optical 3D measuring systems are more and more used in all steps of manufacturing, starting with initial operation, optimization and sampling inspection up to serial control.

Easy to understand variance comparisons to reference models, as well as the simple inspection of dimension,

shape and position ensure the fast evaluation of manufacturing quality and accelerate the tool and process optimizing.

In comparison to conventional tactile coordinate measuring machines optical 3D measuring systems do not only stand out because of higher information density and the fast data capturing process, but in addition by its robustness, easy operation and low maintenance requirements.

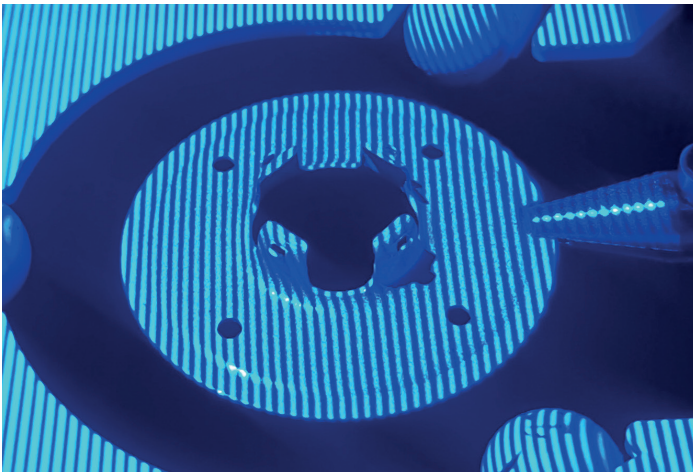

Typical applications:

- Geometrical dimensioning & tolerancing
- Direct comparison to digital reference model (CAD)
- Statistical process control (SPC)
- 3D digitizing and reverse engineering
- Incoming goods inspection
- Initial sampling for tool release
- Automated random sample inspection
- Digitization for design, CAD/CAM and surface reconstruction

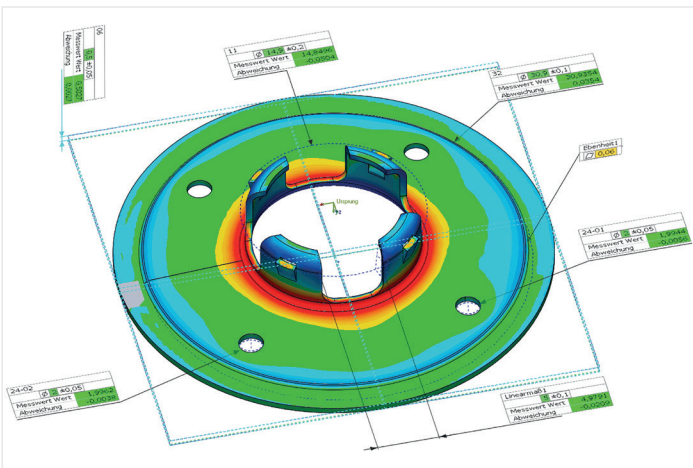

3D dimensioning and variance analysis to CAD

Measurement Systems of FLEX-3A Series

Optical Measuring System for Automated 3D Inspection

Our optical 3D scanners are based on structured-light projection technology for highly accurate and automated part inspection in measurement labs and shop-floors.

The high-resolution scan data is capable of being compared directly against a CAD model, or used for dimensional, shape and positional tolerance measurements.

With object point resolutions down to 5 μm , as well as our smart multi-image referencing using virtual targets, the FLEX-3A is ideally suited for high-precision automated 3D inspection of complex small parts. A closed housing concept, long-term stability of system calibration, the complete automation of multi-view image acquisition, data calculation and evaluation ensure to run the measuring equipment under production conditions.

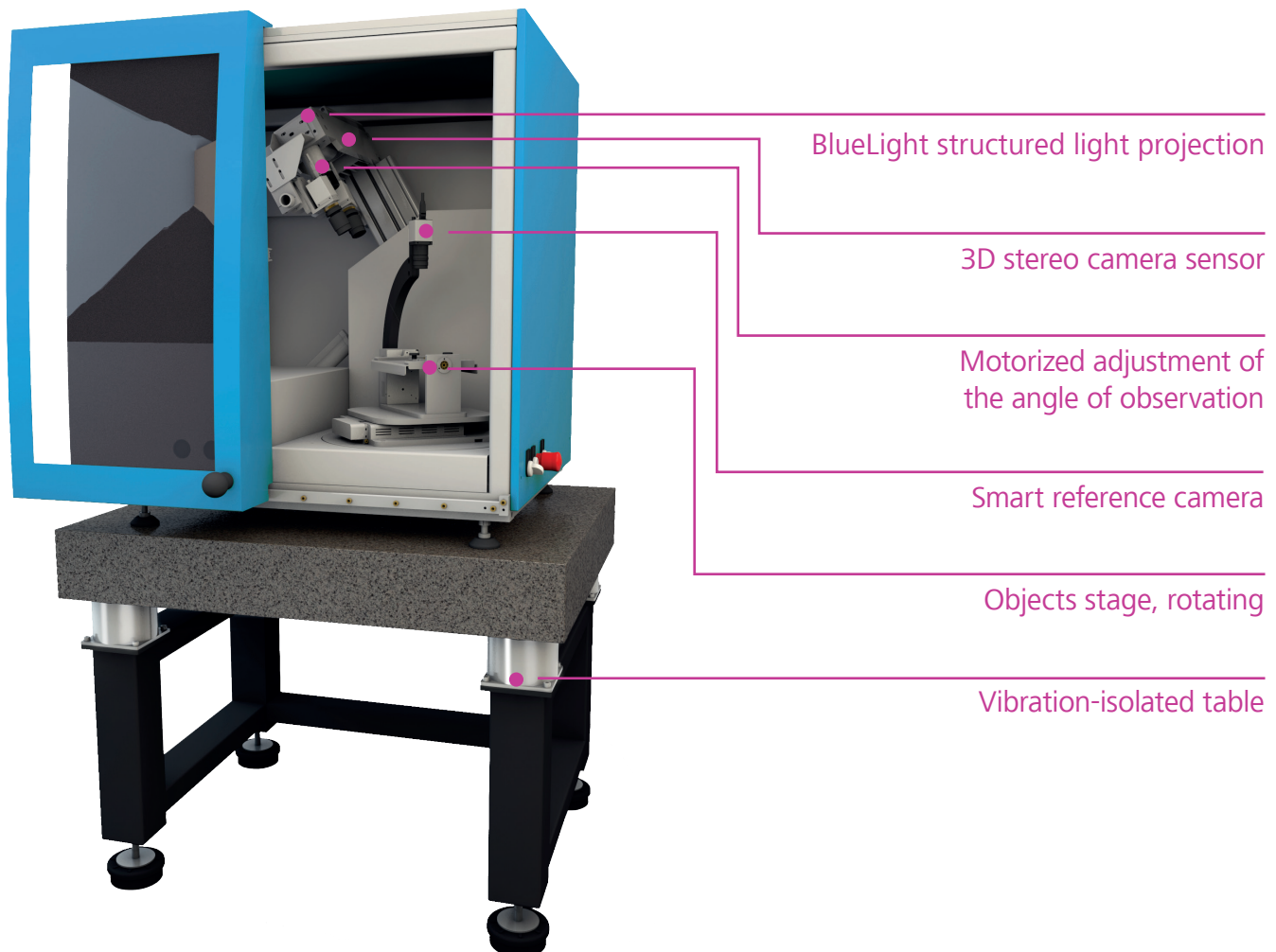

Smart Automatization with Virtual Photogrammetry

Inspection Solution for Highly Accurate Fringe Projection

The patented image acquisition method using a reference camera that is fixed in relation to the object, allows the highly accurate and automated photogrammetric transformation of partial views to a complete 3D model. Physical targets are not required. The two standard motorized axes are fully integrated in the measurement software and can be optionally supplemented by further axes or motion sequences.

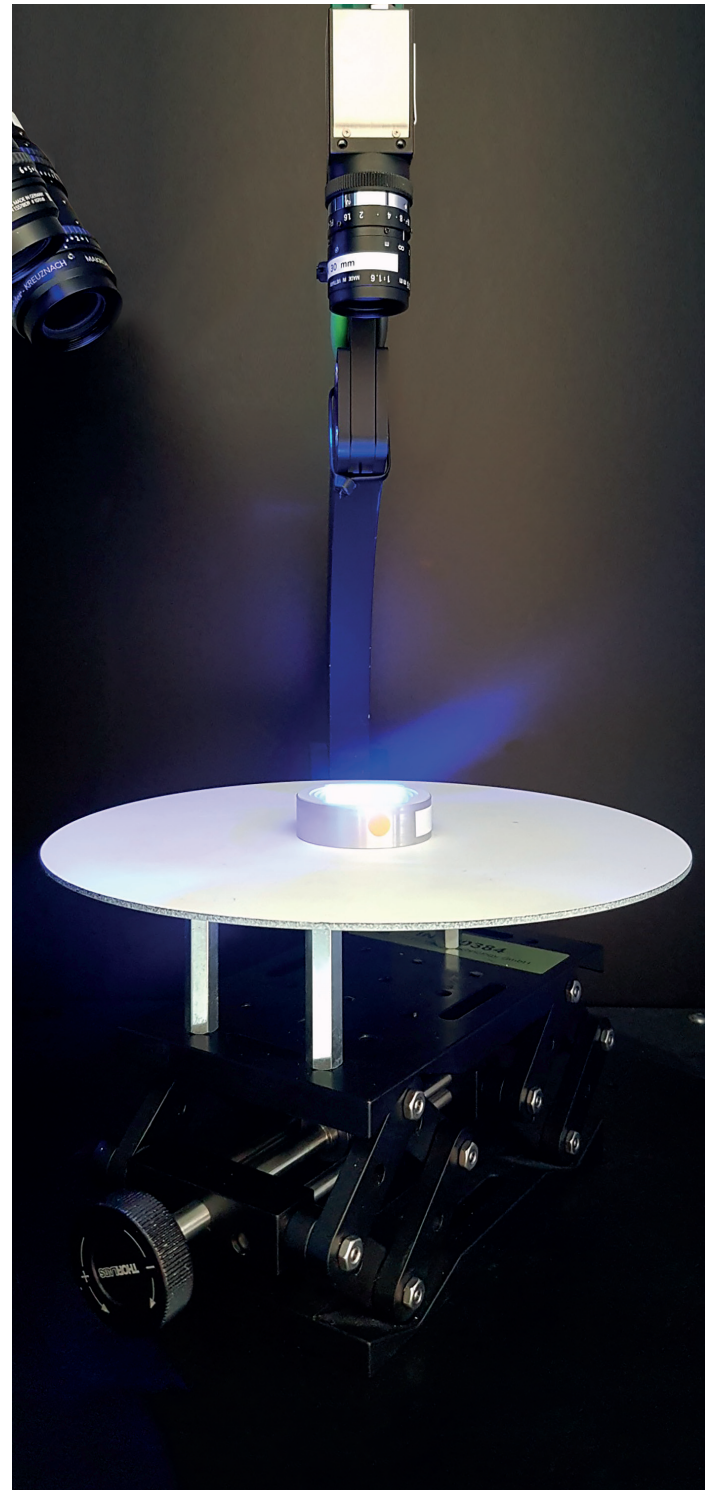

Benefits

Highly accurate and high-resolution scan data

- Camera resolution up to 12 million pixels
- High-resolution BlueLight projection for area scanning with subpixel accuracy
- Small measuring fields with point spacing from 5 μm
- Traceable measuring accuracy according to VDI guideline 2634, sheet 3

Smart virtual photogrammetry

- Photogrammetric registration of all views
- Use of reference cameras to generate thousands of virtual registration targets
- Fully automatic optimization of target number and target distribution





Technical data

Specification	FLEX-3A/12M	FLEX-3A/5M
Available measuring field size	20 mm x 15 mm bis 210 mm x 152 mm	20 mm x 15 mm bis 230 mm x 172 mm
Camera resolution	12 mio. pixels	5 mio. pixels
Data capturing time (per view)	2 s	3 s
Point spacing	5 µm – 50 µm	8 µm – 90 µm
Dimensions (W x D x H)	855 mm x 854 mm x 930 mm	855 mm x 854 mm x 930 mm
Weight	approx. 145 kg	approx. 145 kg
Operating system	Windows 10	Windows 10
Power supply	230 V / 50 Hz / 5 A	230 V / 50 Hz / 5 A
Optional	Vibration insulation table	Vibration insulation table

Available measuring fields

Size (length x width)	Volume (ø x height)
20 mm x 15 mm	ø 18 mm x 5 mm
30 mm x 22 mm	ø 27 mm x 13 mm
45 mm x 34 mm *	ø 40 mm x 20 mm
70 mm x 52 mm	ø 63 mm x 31 mm
100 mm x 75 mm	ø 90 mm x 45 mm
120 mm x 90 mm	ø 108 mm x 54 mm
150 mm x 112 mm	ø 135 mm x 67 mm
210 mm x 157 mm **	ø 190 mm x 95 mm
230 mm x 172 mm *	ø 207 mm x 103 mm

* only available for 5 mio. pixels stereo camera resolution

** only available for 12 mio. pixels stereo camera resolution

Modular Extension Possibilities

Individually Customized and Retrofittable at any Time

The FLEX-3A can be extended in flexible modular manner. The user can select from a broad range of measuring field sizes and automation levels. Standard measuring fields start from 20 mm x 15 mm up to 230 mm x 172 mm.

Further customer-specific solutions are available with larger or even smaller measuring fields up to a point spacing of a

few microns. In addition to the standard motion axes of 3D sensor and object stage proven reference turning frames are applied to enable the fully automated digitizing of upper and lower side.

Additional linear axes with a stroke length up to ± 70 mm, e.g. to capture larger object in several partial steps, can be integrated according to customer demands.

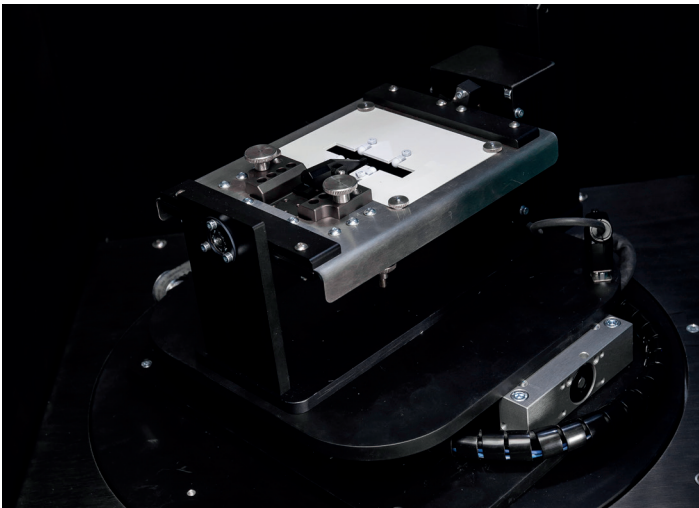

Linear axle and motorized turning frame with object-specific fixation. The integrated reference spheres are used for the automated and highly-accurate combination of upper and lower side of the measurement object.

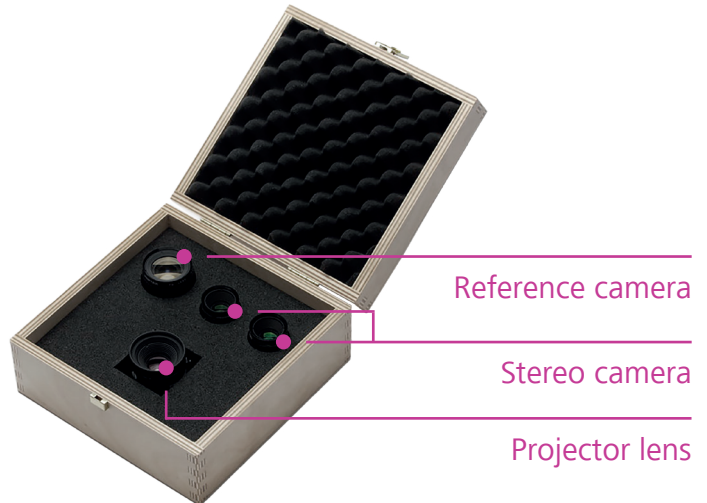

Extension kit for an additional measuring field consisting of four lenses.

Easy to Understand User Concept

Intuitive User Interface and Automated Processes

The clear user concept of FLEXMAN software allows the easy and economical setup of inspection workflows in quality department, as well as on production floor. The following options are available by default:

- Creation of any number of scan plans
- Easy setup of automation workflows without programming
- Support of multiple part measurements
- Automated photogrammetric combination of partial views to global data model
- Calibration monitoring
- Easy sensor re-calibration per mouse click after measuring field change
- Fast point cloud processing
- Direct integration of OVIS Inspect and interfaces to 3rd party inspection suites

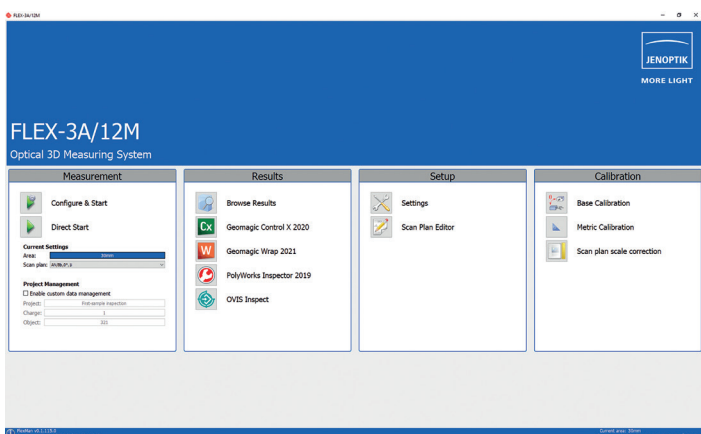
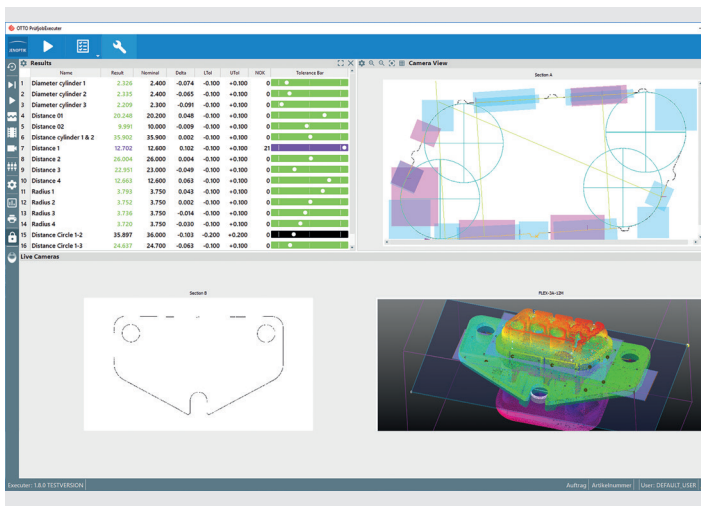

All measuring systems are certified according to the currently valid VDI/VDE guideline 2634, sheet 3. Complying calibrated measurement standards (dumbbells) are used for acceptance. The dumbbell standards are part of the delivery and therefore can be used for monitoring of the measurement accuracy and re-calibration by the user itself.

OVIS Inspect (top);
Main screen FLEX-3A (below)

Variance Comparison to CAD Model

Fast, Meaningful Quality Analyzing

The non-contact optical 3D measuring technology offers the unique opportunity to compare the complete shape of manufactured parts with CAD models promptly and by less effort. Precondition is the capturing of dense three-dimensional point clouds which enable the fast and precise graphical comparison between digital reference models and manufactured parts.

Because of the coloured depiction of deviations critical areas of manufactured parts can be recognized at one glance.

Therefore the user gets direct information to introduce strategies for process optimizing and to initiate steps to eliminate problems.

Respective measuring methods are especially suitable for sample control in manufacturing, the inspection of prototypes and pre-products and the quality management of suppliers. User-friendly reporting, as well as comprehensive options for automation allow the realization of industry- and customer-specific testing requirements.

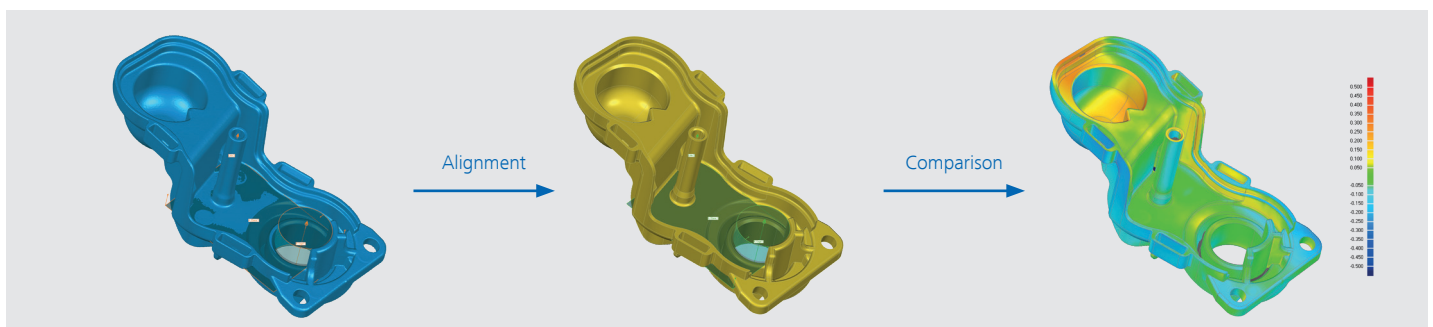

Measured data of an as-built part

CAD/reference model

Coloured/dimensional deviation analysis and reporting

The digitized data of the manufactured part such as point clouds or STL surface data have to be aligned to the coordinate system of the reference model (CAD, reference measurement, etc.). The user can select between different methods like 3-2-1, reference point system (RPS), best fit or a feature-based alignment using any features like planes, vectors, points, etc. Once both models are in a common coordinate system deviations to each other can be illustrated in colour.

Typical global shape deviations like distortion, shrinkage, offset or resilience, as well as sink marks or tool wear can be detected easily. Comparisons between mould cavities or the monitoring of the process stability are possible.

Industries:

- Injection molding
- Stamping, deep drawing, cold forming
- Light metal, zinc die and precision cast
- Additive manufacturing
- Machining industries (turning, milling, eroding)
- Ceramics
- Rubber
- Medical technology

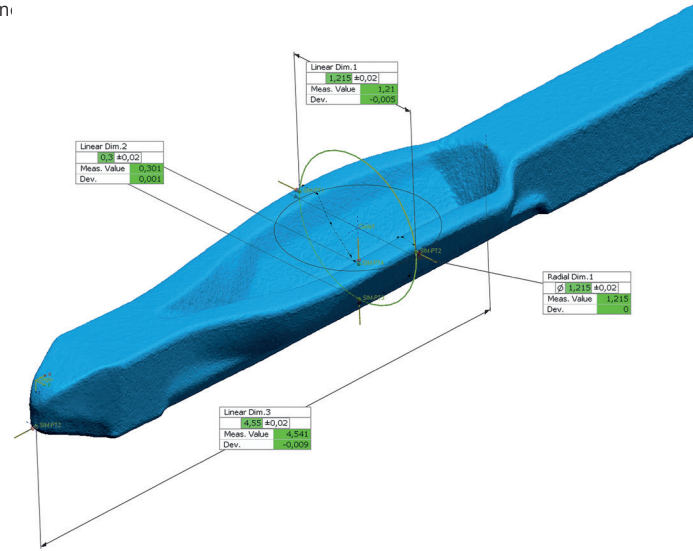

Dimensioning from First Article to Serial Product

In addition to comparisons to CAD model the highly accurate 3D data is used for 3D coordinate measurement as well as for inspection of shape and position.

Our systems support from automated IO/NIO inspection directly at production site up to inspection of first articles and prototypes in the measurement lab.

- 3D coordinate measurement
- Feature based inspection
- GD & T
- Section based dimensioning
- Measurement system analysis

CAD Surface Reconstruction Creation of Digital Models from 3D Scan Data

To process scanned data in CAD software packages, normally a transformation of 3D point clouds into highly accurate surface, polygon and native CAD models is necessary. By 3D creation tools precise and high-quality digital models can be created from new design, prototypes, as well as modified moulds and parts.

Respective parametric models are available for reverse engineering in design, construction, rapid prototyping or further downstream analyzing in CAD programs.

- Creation of accurate digital models in export formats like STEP, IGES, VDA, etc
- Parametric surface modelling by automated and manual classification of surface types (plane, cylinder, sphere, etc.)
- Fully automated creation of complete NURBS surfaces on the basis of polygon models
- Direct export of history-based models to major mechanical CAD packages

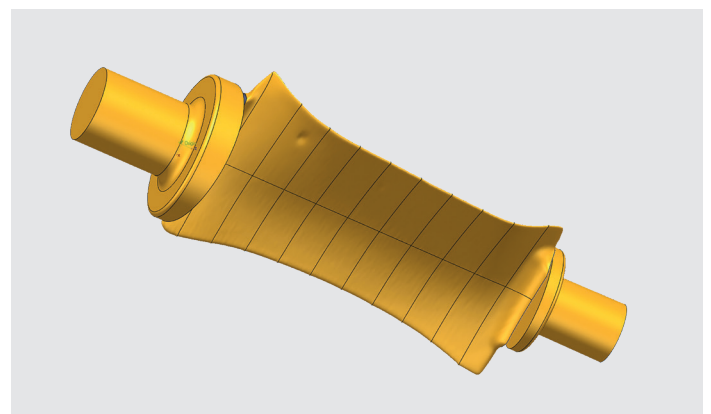
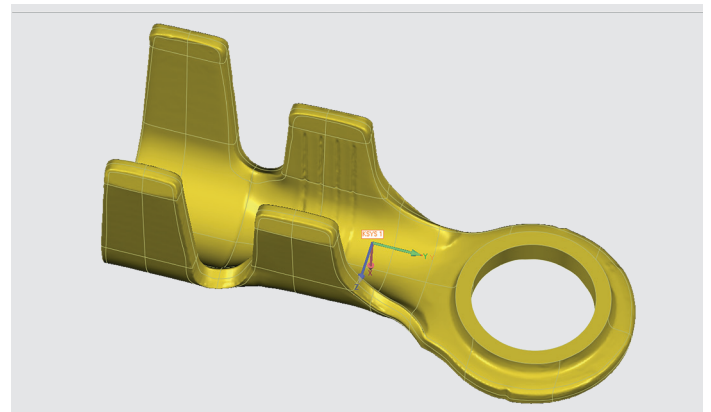

Jenoptik – Worldwide

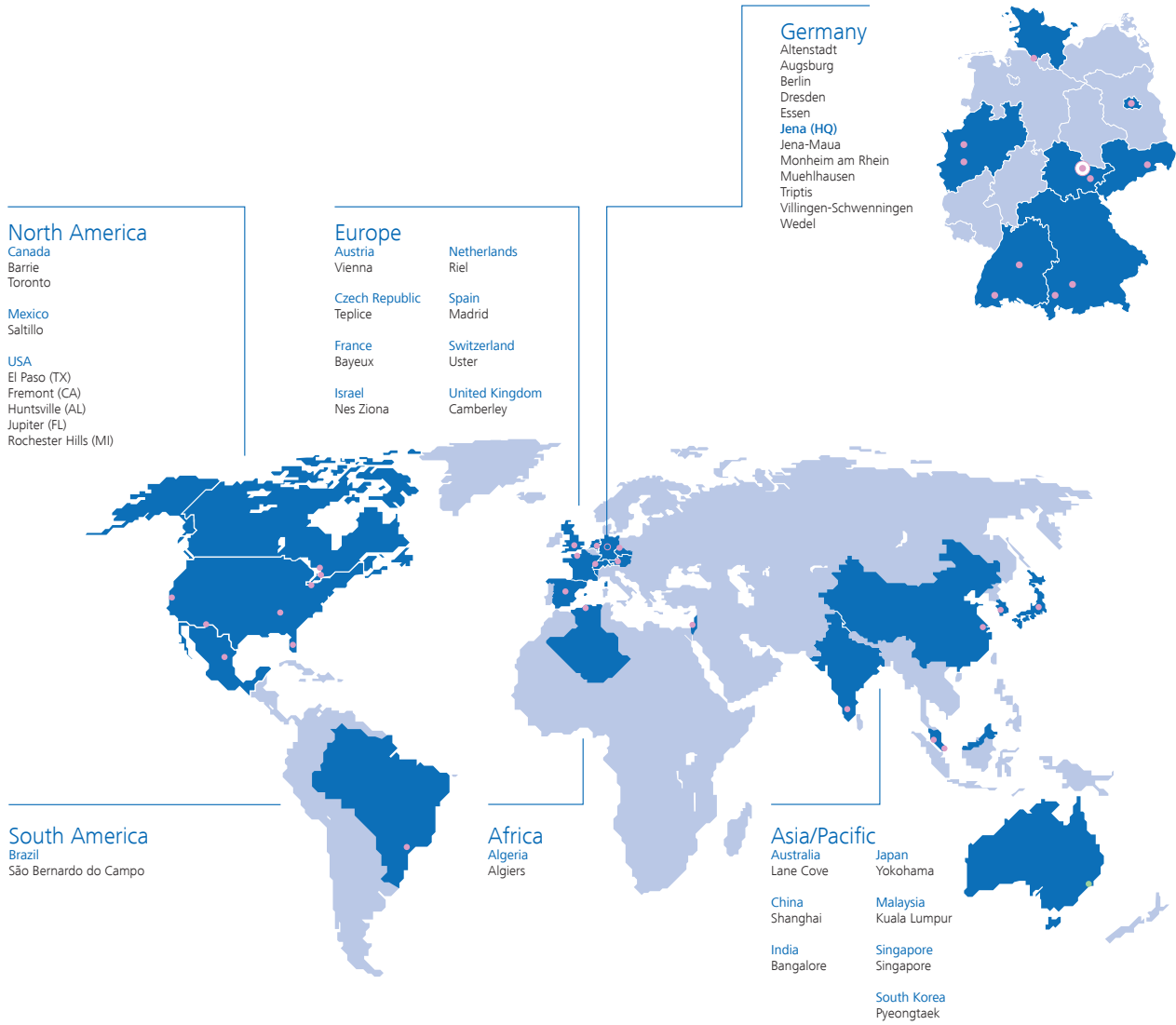

We are a globally operating photonics group which is present in more than 80 countries; the Light & Optics division, for example with production and assembly sites in the USA and China. Additionally, the division is represented abroad by shareholdings in India, Israel, Japan, South Korea and Singapore.

Imprint:

Editor:

JENOPTIK Optical Systems GmbH

Layout:

JENOPTIK Optical Systems GmbH

Images:

Otto Vision Technology GmbH (title, page 2, 7-9)

ART-KON-TOR – DIE AGENTURGRUPPE (page 3-6, 7)

It is our policy to constantly improve the design and specifications.
Accordingly, the details represented herein cannot be regarded as final and binding.
The items may be subject to the German and European Union Export Control Regulations/Laws.



JENOPTIK Optical Systems GmbH · Im Steinfeld 3 · 07751 Jena · Germany
T +49 3641 67-150 · info.otto@jenoptik.com · www.jenoptik.de

